

lis na nebezpečný odpad

press for hazardous waste

FP
5

> vysoká ziskovosť
high efficiency

špeciálny lis na zhutnenie odpadu v 200 litrových sudoch, FP 5 je navrhnutý pre optimálnu využitie sudov a tak vytvára poriadok pričom minimalizuje náklady na likvidáciu odpadu, stroj je k dispozícii aj vo verzii chránenej pred nebezpečenstvom výbuchu

special press for compressing waste in 200-litre barrels, the FP 5 ensures optimal utilization of barrels and an orderly approach whilst keeping disposal costs to a minimum. the machine is also available as an eex-protected model



technické údaje

FP 5		
lisovacia sila compression force	kn	50
motor 400V motor 400v	kw	1,5
max. priemer nádoby max. cans and barrels diameter	mm	700
max. výška suda max. barrel height	mm	900
celkové rozmery lxbxh overall dimensions lwxhxh	mm	880x1000x1950
hmotnosť total weight	kg	215

technical data

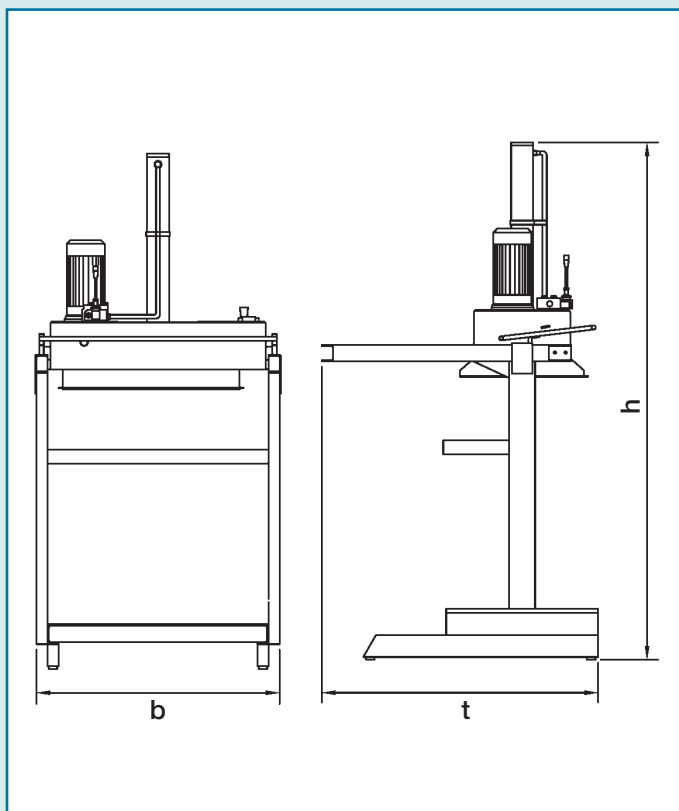

CE zhoda/conformity

technické údaje sa môžu zmeniť - technical data subject to change

produktová rada



product range



Ing. Peter Benko - INECS®
Pri Šajbách 7559/1
831 06 Bratislava
tel.: +421(0)903/427367
peter.benko@inecs.sk
www.inecs.sk



roither maschinenbau gesmbh
a-4863 seewalchen, austria
industriengebiet 11
tel.: +43 (0)7662/8218
fax: +43 (0)7662/8218 21
www.austropressen.com
sale.roither@austropressen.com



druck- und satzfehler sowie irrtümer vorbehalten. agentur i&lm, www.i&lm.at