



lisy na plechovky a sudy

can and barrel presses

DS

7

10

FP

200

300

- > maximálne jednoduché použitie
highest comfort

maximálne jednoduché použitie vďaka tlačidlovému ovládaniu a dvom plniacim dverám
easy to handle with push button control and two filling doors



- > maximálna bezpečnosť
maximum safety

maximálna bezpečnosť vďaka uzavretej konštrukcii
maximum safety due to closed construction



- > mnohokrát dokázané
long time experience

lisovacia doska je vybavená hrotmi a zvyšková kvapalina, ktorá uniká počas kompresie, sa zhromažďuje v zbernej miske
press ram is fitted with spikes, any liquid residues are collected within a sump

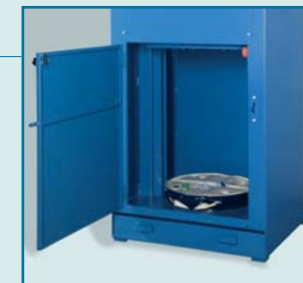

- > eex chránené
eex protected

stroje sú k dispozícii aj vo verzii chránenej proti výbuchu
machines are also available in eex-protected version



DS 7 10

lisy na plechovky a sudy

can and barrel presses

- > všestrannosť
universal application

všestranný stroj na lisovanie nádob do 60 litrov, zberná vanička na zvyškovú tekutinu

flexible use for reducing tins up to 60 litres, any liquid residues are collected within a sump



FP 200 300

- > vysoká ziskovosť
high efficiency

lisy na plechovky a sudy sú navrhnuté na redukovanie objemu plechových nádob až do veľkosti 200 litrov, FP 300 je obzvlášť vhodný na lisovanie spevnených sudov alebo sudov naplnených ďalšími menšími sudmi

can and drum crushers are designed to reduce the volume of containers and barrels up to 200 liters, FP 300 is designed to manage heavy gauge barrels and drums containing other cans with its exceptionally strong compaction force



		DS 7	DS 10	FP 200	FP 300
lisovacia sila <i>compression force</i>	kn	70	100	200	270
motor 400V <i>motor 400v</i>	kw	1,5	1,5	4	5,5/7,5
lisovací cyklus <i>comp. time incl. return stroke</i>	sec	30	50	50	60/50
max. priemer nádoby <i>max. cans and barrels diameter</i>	mm	400x500	400x620	700x950	700x950
kapacita <i>capacity</i>	h	80	50	60	50/60
celkové rozmery lxbxh <i>overall dimensions lwxhx</i>	mm	630x810x2150	630x810x2150	1000x890x2450	1000x940x2470
hmotnosť <i>total weight</i>	kg	285	320	770	942/970

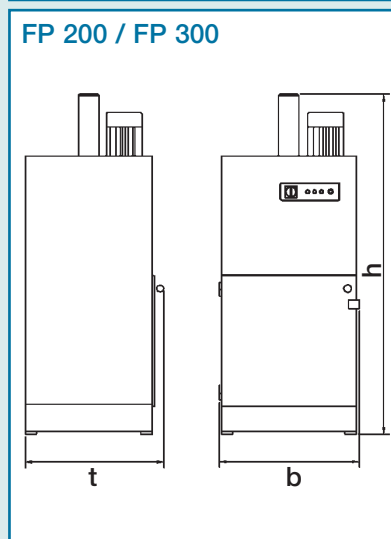
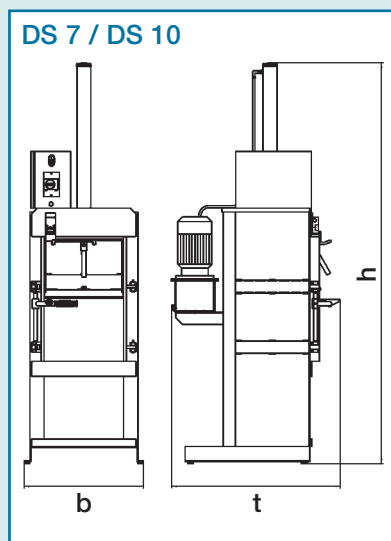

CE zhoda/conformity

technické údaje sa môžu zmeniť - technical data subject to change

produktová rada

product range



Ing. Peter Benko - INECS®
 Pri Šajbách 7559/1
 831 06 Bratislava
 tel.: +421(0)903/427367
 peter.benko@inecs.sk
 www.inecs.sk



roither maschinenbau gesmbh
 a-4863 seewalchen, austria
 industriegebiet 11
 tel.: +43 (0)7662/8218
 fax: +43 (0)7662/8218 21
 www.austropressen.com
 sale.roither@austropressen.com



druck- und satzfehler sowie irrtümer vorbehalten. agentur l&h, www.lum.at