



Dewatering reject from paper mills

Technical data specification SK370

Dimensional drawing

Subject to technical modifications.

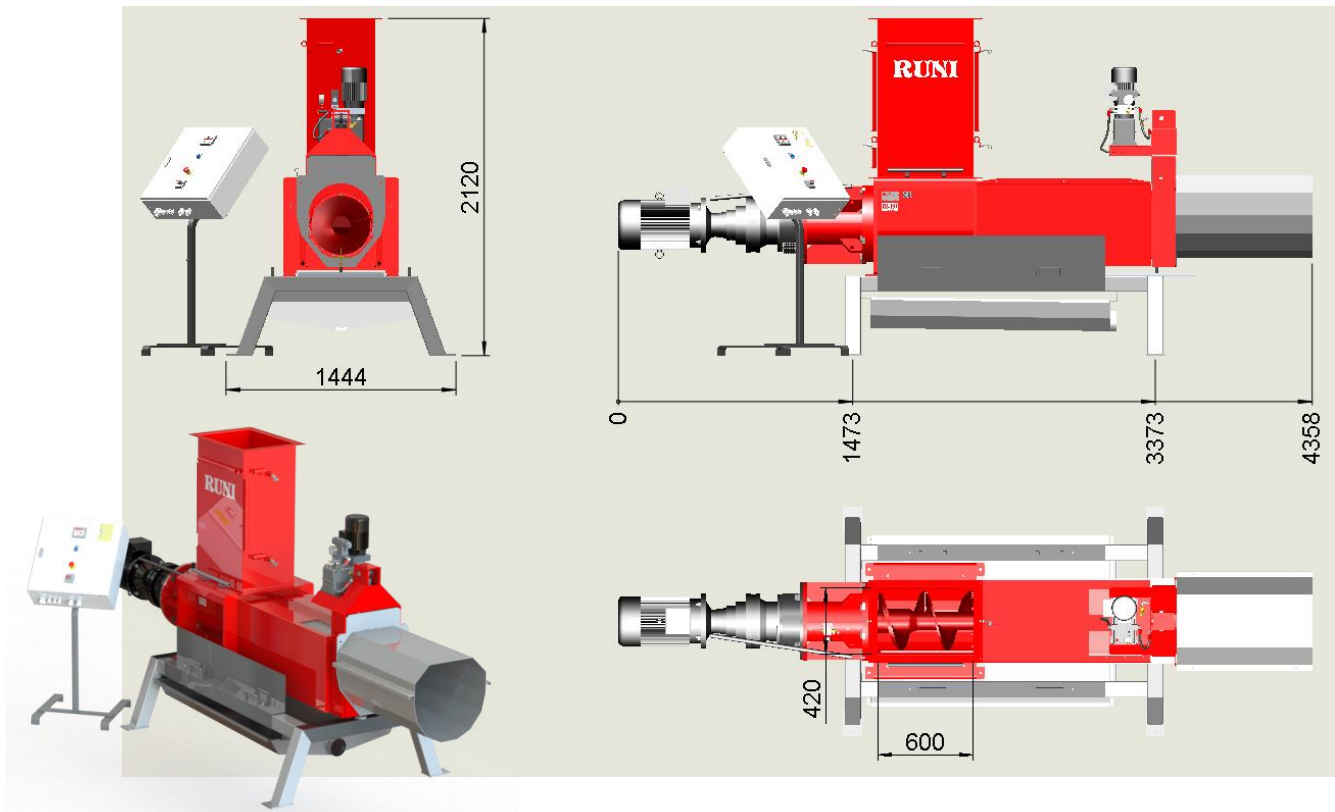

Technical data	Europe	USA
Material	Reject from paper mills	Reject from paper mills
Achieved dry matter percent *)	75 %	75 %
Capacity per hour	5000 kg	11000 lbs
Daily capacity	120 tonnes	120 ton
Feed opening dimension (standard)	600 x 420 mm	24 x 17 inch
Weight	1500 kg	3300 lbs
Machine dimension (LxBxH) (standard)	4358 x 1444 x 2120 mm	171 x 57 x 83 inch
Motor power	Main motor: 15 kW Hydraulic pump: 0,55 kW Oil cooling for gear: 0,07 kW Oil cooling for hydraulic: 0,07 kW Circulation pump: 0,25 kW	Main motor: 24 hp (18 kW) Hydraulic pump: 0,9 hp (0,66 kW) Oil cooling for gear: 0,17 hp (0,13 kW) Oil cooling for hydraulic: 0,17 hp (0,13 kW) Circulation pump: 0,38 hp (0,29 kW)
Power supply	3 x 400V, 50Hz, 63A	3 x 230V, 60 Hz, 80A 3 x 480V, 60 Hz, 63A
Marking	CE approved	CE-approved, UL(only components)

*) Depending on percent of paper fibres.



Dewatering reject from paper mills

Description

RUNI screw compactor is able to dewater the reject in a continuous process leaving the reject dry enough to send it to incineration instead of sending it to landfill at much higher cost. The conditions at a paper mill are extremely demanding and plants are working 24/ all year round. In the waste material (reject) there are often abrasive elements like sand. Therefore great demands are required of the machine and RUNI can do it.



65 %  25 %
 Reduction of water content



Function

The Integrated sensors automatically start and stop the machine. The water is collected in the stainless steel tray below the machine and can be diverted from the area. The machine reports when it is time to grease the bearings every 100 hour. The screw compactor can be installed as the last link in the line. The machine can be fed with material via conveyor belt or directly under a rotating drum.



Benefits

- Dewatering reject at low cost.
- Matrix in stainless steel (AISI316).
- Safe and easy operation with automatic start and stop.
- Hard metal on screw ensures long lifetime.

Option

- Frequency converter for adjusting speed.
- 2-3 machines on same console.