

WEIMA shredders for plastics and recycling

Series WLK Heavy demand models



WLK 12 · WLK 15 · WLK 18 · WLK 20

Performance profile

The larger models of the WLK series are designed for high throughput quantities and are suitable for processing almost all plastics. The machines will shred production waste, pipes, automotive parts, blow-moulded materials such as for example PET bottles, PE/PP bottles, containers or buckets without problems, and also paper, cardboard, light metals.

Various sizes and different versions guarantee optimum adjustment for every application. Options such as the patented V-rotor with adjustable counterknife so called Supercut allow for first-class shredding results. WLK shredders can be belt or manually fed or loaded by fork-lift trucks. They are also ideal as preliminary shredders integrated into a two-stage operation.

The WLK Series – an overview

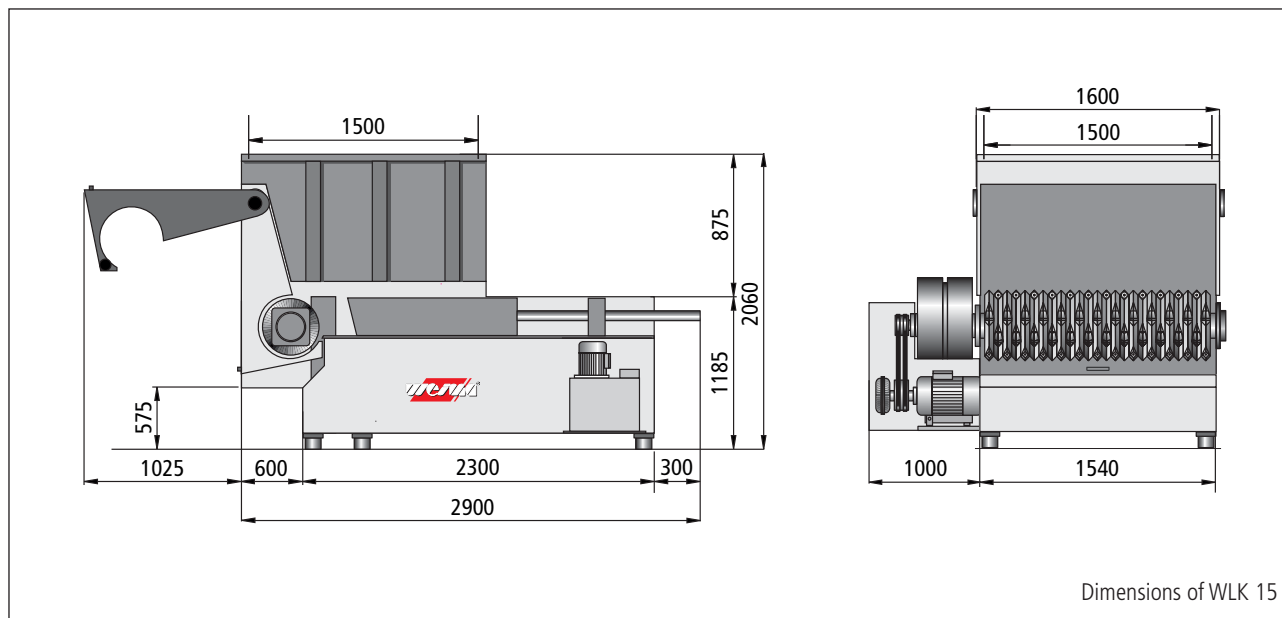

SPECIFICATIONS

	WLK 12	WLK 15	WLK 18	WLK 20
Number of knives	(34) 64	(43) 82	(52) 100	(57) 110
Feed opening (mm)	1.200 x 1.200	1.500 x 1.500	1.800 x 1.500	2.000 x 1.500
Hopper capacity (m ³)	1,6	2,5	3,0	3,3
Rotor diameter (mm)	368	368	368	368
Rotor speed (rpm) approx.	85	85	85	85
Motor performance (kW)	55 / 75 / 90	55 / 75 / 90	90 / 110	110 / 132
Screen perforation (mm)	15 - 100	15 - 100	15 - 100	15 - 100
Weight (kg) approx.*	4.700	6.500	7.500	9.000

* This may vary according to equipment and drive performance of the machine.

EQUIPMENT

Standard series equipment

- patented V-rotor for optimum even cutting geometry
- concave-ground cutting knives
- hydraulic horizontal feed ram, load-sensitive control
- moveable screen basket for quick rotor access and screen changing
- low maintenance, offset and sealed rotor bearings
- memory-programmable control (PLC)

Optionen

- rotor with welded-on or screwed-on knife holders
- Supercut for precise adjustment of cutting gap
- feed ram extra options: turbo-hydraulics, pusher segmented feed, ram comb
- pipe spacer funnel for controlled material feed of large parts
- rotor cooling
- hydraulic oil and gearbox oil cooling
- Hardox coating for rotor
- hydraulic press-down device

Drive

WLK shredders are available with the option of mechanical, hydraulic or patented high-torque CDW drive (Compact Drive WEIMA).

Options for increased safety: gearbox limit switch, reverse counter, hydrodynamic clutch, KTR safety clutch, safety switch.